

# ORBIT - V

Automatic PVC Corner and Surface Cleaning Machine



## FEATURES

Used for simultaneously welding four corners of PVC / Vinyl profiles and removing the burrs from the profiles after welding.

- Batch processing and precision measurement
- Touchscreen control panel and profile recognition system
- Cleaning of bottom, top, internal and external surfaces of the profile by two independent cleaning units
- Manual operator adjusted axial speeds
- Memory capacity for 1000 profiles
- Automatic cleaning with 11 profile cleaning blade
- Separate cleaning blades for colored and white profiles
- Alarm and warning sign on screen

## Standard Equipment

- Profile external cleaning saw blade
- Cleaning blades
- Cutters

The product data, descriptions and illustrations are shown for advertising purpose in this document and Oz Machine, reserves the right to make modifications or improvements on data, descriptions and illustrations on this document without prior notice.

# ORBIT - V

Automatic PVC Corner and Surface Cleaning Machine



## FRAME DIMENSIONS

X Axis (Longitudinal)	13 3/4" x 15 3/4" (350mm x 400mm)
Y Axis (Lateral)	100" x 157 1/2" (2540mm x 4000mm)

## PROFILE DIMENSIONS

Minimum Profile Height	1 3/16" (30mm)
Maximum Profile Height	7 7/8" (200mm)
Minimum Profile Width	1 3/16" (30mm)
Maximum Profil Width	5 15/16" (150mm)

## CUTTING UNIT

Saw Blade Diameter	11 13/16" (300mm)
Spindle Power (for saw blade)	1.5 kW
Spindle Rotation (for saw blade)	6000 rpm
Saw Blade Thickness	1/8" (3.2mm)
Spindle Power (for router bit) (x2)	1.1 Kw
Spindle Power (for router bit)	18000 rpm
Router Bit Dimensions	5/16" (8mm)
Router Bit Length	4 3/4" (120mm)

## ELECTRICITY & AIR

Voltage	220V 3N PE AC
Frequency	50 - 60 Hz
Power	7 Kw
Air Pressure	6-8 bar
Air Consumption	25 Gal/min

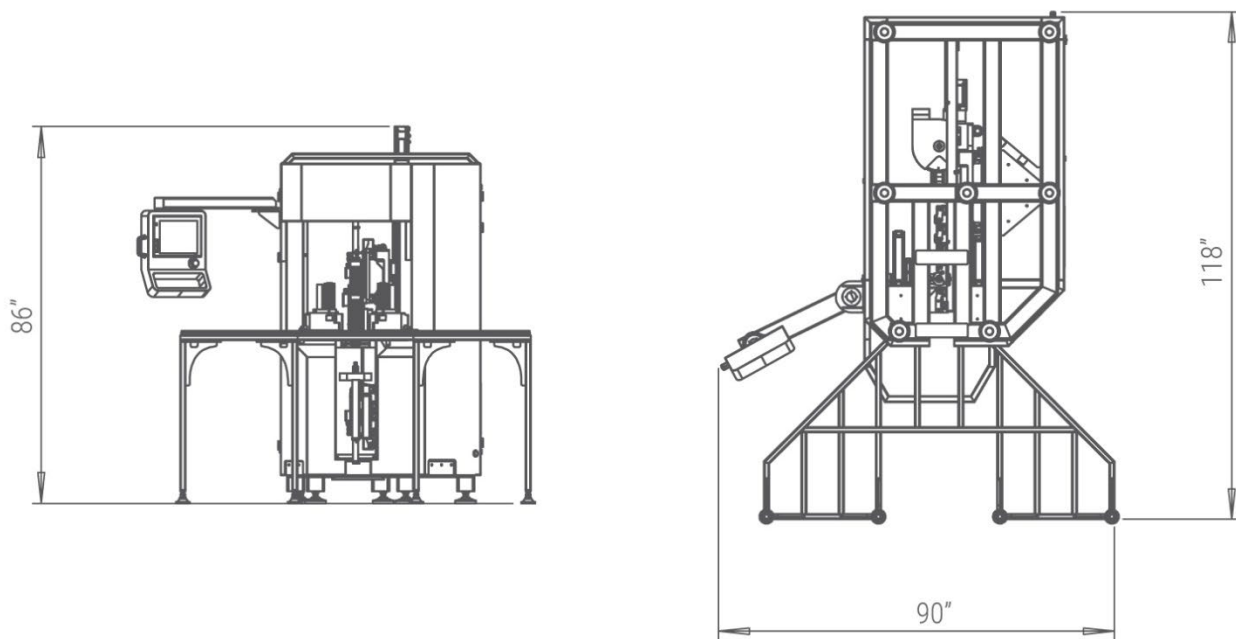

The product data, descriptions and illustrations are shown for advertising purpose in this document and Oz Machine, reserves the right to make modifications or improvements on data, descriptions and illustrations on this document without prior notice.