



FEATURES

Used for V cutting, arrow cutting, 45° cutting and 90° notching processes of aluminum and PVC (Vinyl) profiles.





- Wide profile cutting with Ø 500 mm saw blade
- Hydro-Pneumatic cutting process
- Adjustable saw blade travel speed to the profiles
- Double hand start

Standard Equipment

- Ø 3 15/16" saw (2 pcs.)
- Cooling system
- V cutting set with Pneumatic clamps

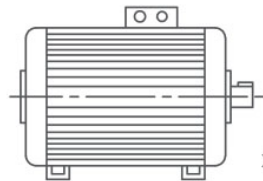
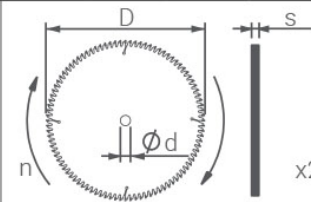
Optional Equipment

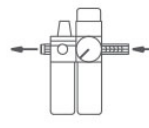
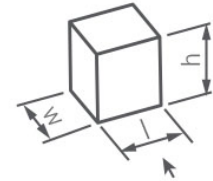
- Right and left conveyor (90° notching, 59")
- 90° notching set with Pneumatic clamps
- Right and left conveyor (V cutting, 119")

											
HP kW	n	3~ Hz	I (400 V)	Ø D	Ø d	s	n	Air Pressure	Air Consumption	l x w x h (inch)	lbs
4 3	2900 r.p.m	50	6,6 A	19 1/16"	1 3/16" 1 5/16"	3/16"	2340 r.p.m	87-116 psi	14 gal / min.	46 x 45 x 78	1190

The product data, descriptions and illustrations are shown for advertising purpose in this document and Oz Machine, reserves the right to make modifications or improvements on data, descriptions and illustrations on this document without prior notice.